

	KG	WINDAGE
<b>ZEBSTAR</b>	1.75kg	0.088m <sup>2</sup>
<b>ZEBSTAR+</b>	2.5kg	0.104m <sup>2</sup>

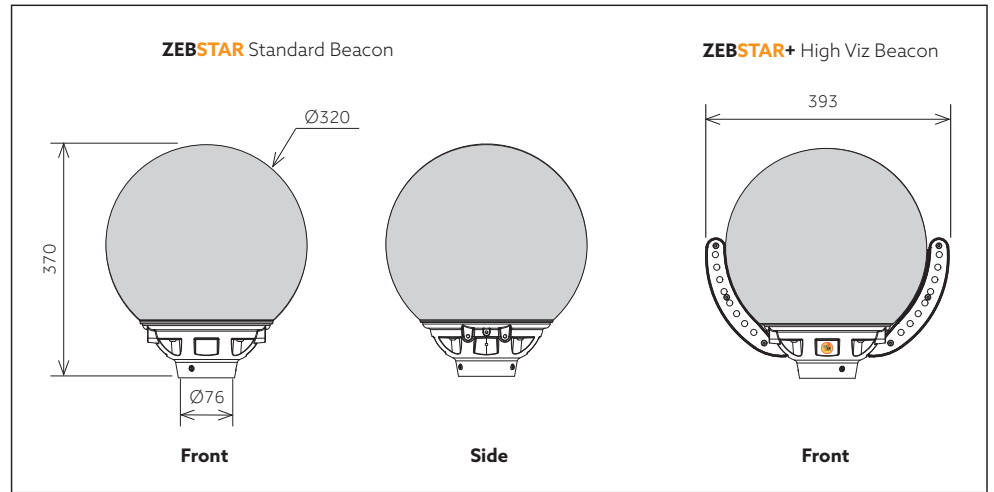
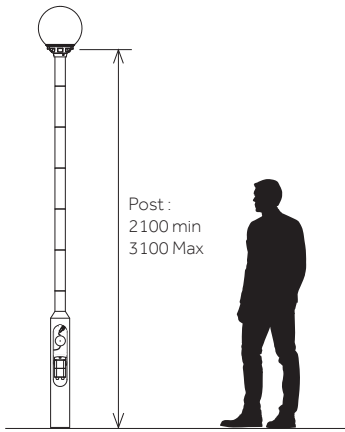

- Disconnect Beacon from the supply when conducting in-situ insulation resistance testing.
- If the external flexible cable or cord of this beacon is damaged, it shall be exclusively replaced by the manufacturer or his service agent or a similar qualified person in order to avoid a hazard.
- The light source (LED's) contained in this beacon shall only be replaced by the manufacturer or his service agent or a similar qualified person.

**SAFETY FIRST**

Isolate the electrical supply before commencing any installation or maintenance work. Wiring should be carried out in accordance with the latest IEE regulations by suitably qualified engineers.

This equipment is designed for 24 volt AC operation and must be used with a suitable transformer when connected to the mains supply. .

**TOOLS REQUIRED**

- 4mm Allen Key
- Philips Screwdriver
- 7mm Drill

**1**

Drill a 7mm hole 42mm down from the top of the post and at 90° to the traffic flow on the kerb side .

Alternatively take the assembled beacon and identify the dog point socket set screw. Place the beacon on top of the post and align to the traffic flow. Tighten the dog point screw in order to mark the post.

Remove the beacon and drill a 7mm hole in the marked location.

**2**

Take the beacon assembly and pass the pre-wired cable down the post and pull it through into the base compartment.

Place the beacon on top of the post with the yellow BEE SEEN logo facing away from the approaching traffic.

Tighten the 3 socket set screws. One of the screws has a dog point which should engage in the drilled hole to prevent rotation.

**3**

Move to the base compartment and fix the beacon transformer onto the column board using the 4 screws provided.

Connect the beacon supply cable to the power supply using the supplied connector. Coil and secure any excess cable neatly in the base housing.

Connect the transformer input cable to the incoming power supply at the fused cut-out.

**4**

Re-connect the electric supply and replace the base door. Check that the beacon operates correctly.

**Synchronising Beacons.** Several beacons may be synchronised by powering up at the same time or timing the powering of one beacon to match the other.\*

**ZEBSTAR+** The intensity of the Bee Seen ZEBSTAR+ beacon is factory set to medium power. Please see over for instructions on how to adjust the brightness should this be required.

\*Dependent upon mains quality

## ZEBSTAR+ POST TOP BEACON ARRAY BRIGHTNESS ADJUSTMENT

The ZEBSTAR+, post top beacon has a remotely adjustable array brightness which is independent between front and back. Follow the steps below to make the adjustment.

### SAFETY FIRST

Adjustment of the ZEBSTAR+ array is carried out with the beacon powered up. Ensure that you are in a safe location when carrying out the adjustment.

### TOOLS REQUIRED

- Portland Traffic Infra-Red Handset (supplied with beacon)

Identify the front of the installed beacon which displays the yellow BEE SEEN Logo.  Check the logo has a red border which indicates it can be used with the Infra-Red adjustment system. Safely move into a position where you are able to point the Infra-red remote at the front of the beacon. When using the Infra-Red Handset for the first time, pull the clear battery isolator tab to connect the battery.

### 1. SET THE ZEBSTAR+ HI-VIZ ARRAY BRIGHTNESS

Press



Pressing this for 3 seconds\* will put the ZEBSTAR+ into programming mode. This will cause the ZEBSTAR+ globe to switch off and the Hi-Viz array to be permanently on. The arrays will show the currently stored brightness setting.

\*Ensure the button is held until the ZEBSTAR+ globe switches off



Use the up and down arrow keys to adjust the Hi-Viz array brightness to the preferred level. Each time a button is pressed the beacon will flash once to confirm the instruction. When the brightness reaches the upper (level 7) and lower (level 0) brightness limit the beacon will double flash to indicate the limit has been reached.

At this point Front and Back arrays are set to the same brightness

### 2. SET THE BRIGHTNESS OF THE REAR ARRAY

Press



This will allow the rear array to be set to a different level to the front array. In this mode the rear brightness will also be shown on the front array so that you don't have to go to the other side of the beacon.



Use to adjust the rear Hi-Viz array brightness to the preferred level.



Stores the brightness of the rear array and returns the front array to the active level previously set in 1 above.

### 3. NIGHT MODE

Press



This button allows the Hi-Viz arrays to be automatically switched off at night. When pressed, the beacon will flash twice to indicate the arrays will be switched **OFF** at night. Press again and the beacon will flash once to indicate that they are switched **ON** at night. When on at night, the arrays will be set to level 1 which is a similar brightness to the beacon.



The Demonstration button will show the arrays at the selected night mode brightness saved by the beacon. Press again to return to programming mode.

### 4. CLOSE PROGRAMMING MODE

Press



Press to close program mode, save the current settings and return to normal operation. This can be pressed at any time.

Closing the program mode also re-sets the beacon flash timer to the start of the on cycle. By observing another beacon and timing the button press it is possible to get the beacons to flash together. Beacons can also be synchronised by powering them up together or powering one to match the other(s).